

Ford Everest Gen 2 Fitting Instruction (6-22 Onward)



WT-FE2-2013

Congratulations on the purchase of your Australia made Wedgetail Roof Rack product, please follow these instructions to ensure correct fitment.

STEP 1:

Lower the interior head lining to expose (M6 roof rail securing nuts)
Remove nuts and factory fitted roof rails (6 slotted holes per side)



STEP 2:

Now fasten wedgetail mounting lugs (Use M6 sems Bolts provided & existing Ford rail nuts)

- 2 Middle
- 2 Front (Left Hand & Right Hand)
- 2 Rear (Left Hand & Right Hand)

Please use sealant under lugs and around fasteners (Neutral Cure non-corrosive silicone/ sealant)

Front Orientation

- Pre-bend front shape to follow roof contour



Middle Orientation



Rear orientation





STEP 3:

Attach Rails to lugs using 10mm hardware with the wedgetail logo facing to the front of the vehicle. Refer to the diagram (do not tighten fully)

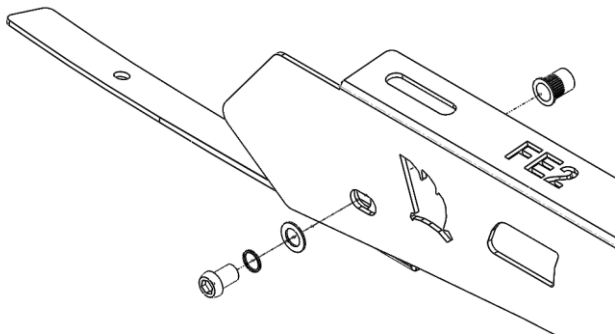

STEP 4:

Fit 10mm Bolt / Split washer / Flat washer / Channel Nuts to the top of rail.

**Channel nuts to the top as shown in the next diagram*

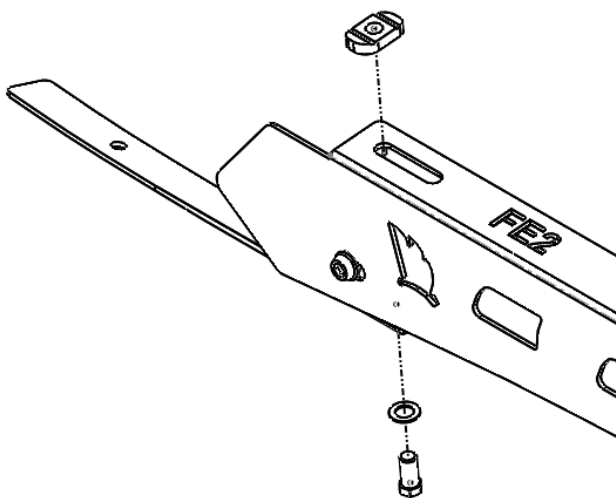

STEP 5:

Place the Wedgetail Platform on the rails (Wind deflector mounting towards the front of vehicle), then spin the channel nuts 90 degree in the

channel on the underside of the rack till they lock into the channels. Do not tighten fully

STEP 6:

Centralize the rack side to side (using a tape measure) on the wedgetail rails.

STEP 7:

Fully tighten remaining bolts in the following order:

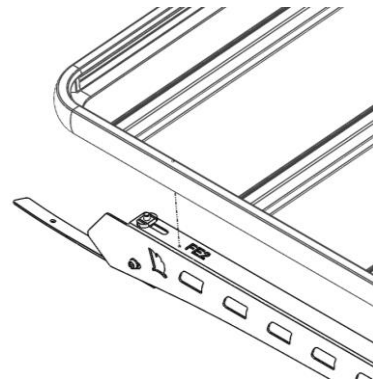

- a) Rail to the Lug
- b) Rails to Platform

* ensure the channel nuts are 90 degree to the channels

- c) Attach wind deflection

Check fastenings are firmly tensioned at regular intervals

Do not overtighten, this will preserve the spring washers.

Thank you for your purchase.

Please complete your warranty application following correct installation.

**Wedgetail by Tradesman Roof Racks
Innovation through Inspiration**