



Ford Ranger Extra Cab Fitting Instructions

INSTALLING RAILS AND ROOF RACK:

Congratulations on the purchase of your quality Australian made Wedgetail Roof Rack product, please follow these instructions to ensure a safe and correct fitment.

The photos below indicate where the mountings are to be positioned and the roof channel rubber should be cut to allow the Wedgetail Rail mounting lugs to be riveted within the roof channel.

- To cut the roof rubber, first mark the strip cut locations with a suitable marker. Then lift the rubber trim using a suitable panel leaver. The strip can then be cut in the appropriate place with a sharp Stanley knife.
- You should ensure the cut sections correspond with the 2 centre mounting holes in the Wedgetail rail prior cutting the rubber. Also the Roof rack should be positioned according to your desired position on the roof taking into consideration wind deflector
- When drilling rivet mounting holes ensure you use a Drill stop on your drill to ensure headlining, wiring or curtain airbags are not damaged.

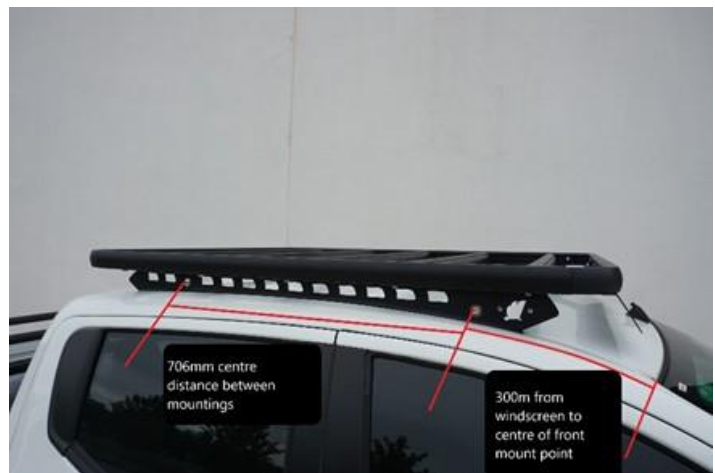

The below positions are guide regarded as best position (please double check prior drilling)

Centre of Front Mounting Lug approx 300 mm from windscreen edge

Centre distance between Front Mounting Lug & Rear Mounting Lug 706mm

Mounting Lug Fitments

1. Place mounting Lug in the roof channel as per measurements shown in above diagrams. Drill all 4 mounting holes in each lug using a 5mm drill with drill stop, drilling one at a time then placing a rivet through hole to keep lined up (DO NOT RIVET IN PLACE YET) before drilling the next.
2. Paint all holes using either an enamel or acrylic paint (to apply you can use a cotton bud if paint brush is not available).
3. Apply silicone or urethane sealer (natural cure sealants only) to the 5mm drilled rivet holes.



4. Attach lugs to the roof of vehicle using 5mm rivets and as shown.

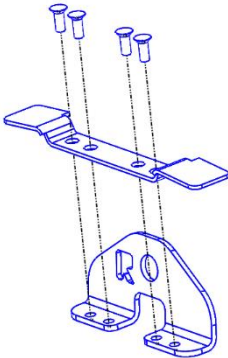

This fitment uses Structural Non-Sealed rivets for strengthening reasons

Silicon must be applied to the top of the rivet to prevent water ingress.

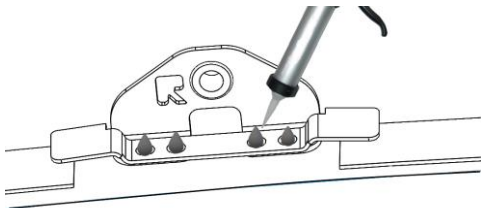

5. Attach Rails to lugs using 10mm hardware with the wedgetail logo facing to the front of the vehicle. Refer to the picture.
6. Fit 10mm Bolt / Split washer/ Flat washer with the channel Nuts on top of rail.
*Channel nuts to the top as shown in the next diagram

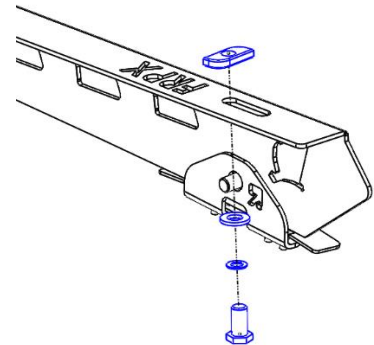
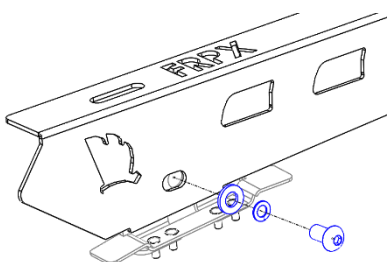

7. Place the Wedgetail Platform on the rails (Wind deflector mounting towards the front of vehicle), then spin the channel nuts 90 degree in the channel on the underside of the rack till they lock into the channels. Do not tighten fully.
8. Centralize the rack side to side (using a tape measure) on the wedgetail rails.
9. Fully tighten remaining bolts in the following order:
- Rail to the Lug
 - Rails to Platform
* ensure the channel nuts are 90 degree to the channels in the platform
 - Install wind deflector using 8mm hardware

Note: Check fastenings are firmly tensioned at regular intervals.

Do not overtighten, this will preserve the spring washers.

Thank you for your purchase.

Please complete your warranty application following correct installation

Wedgetail by Tradesman Roof Racks

Innovation through Inspiration