

Congratulations on the purchase of your Australian made Wedgetail Roof Rack product.

Please read and follow the instructions carefully to ensure correct fitment.

Contact us if any parts appear missing, incorrect, or damaged.

Contact us if any question about the size of platform to ensure the correct fitment

Tools Required:

- Hex key (6mm)
- Spanner (17mm)

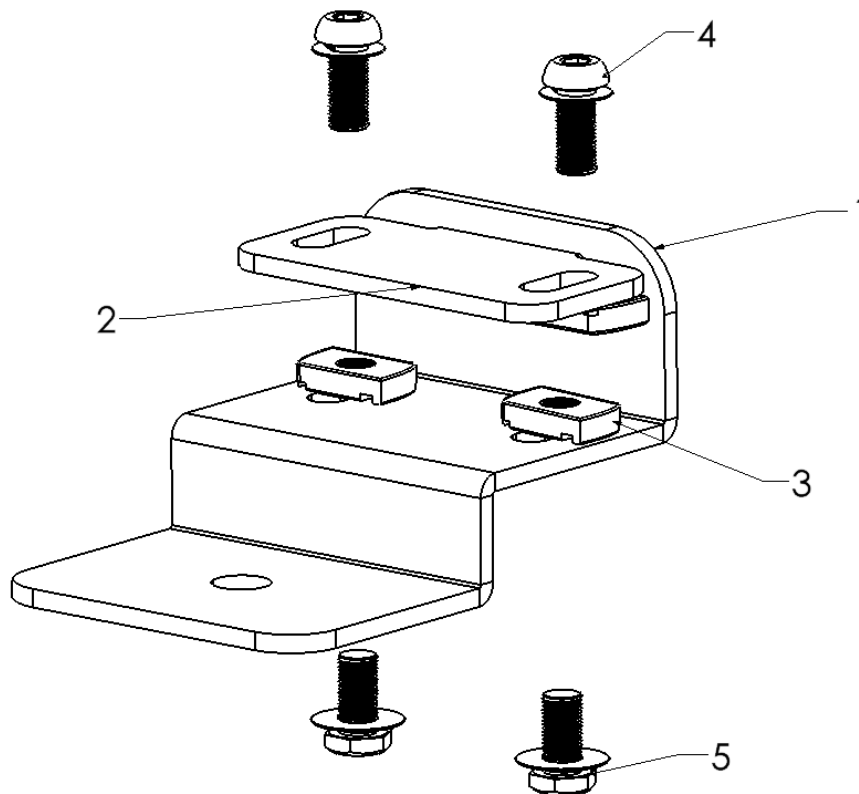

KIT CONTENTS

ITEM	COMPONENT	QTY	ITEM	COMPONENT	QTY
1	Wedgetail Aerial Mount Holder	1	4	M10 x 25 Dacro	2
2	Wedgetail Aerial Mount Support Plate	1	5	M10 x 20 Stainless Hex Bolt	2
3	M10 Unistrut	4			

Wedgetail Accessory Recessed Aerial Mount Bracket

Fitting Instruction



WTA-AM

1

- Assemble the Aerial mount holder under the cross bar using the channel nuts and M10 Hex Bolt. Refer to the diagram.

NOTE-Ensure the channel nuts are 90 degrees to the channels.

Check fastenings are firmly tensioned at regular intervals.



Do not overtighten, this will preserve the spring washers.

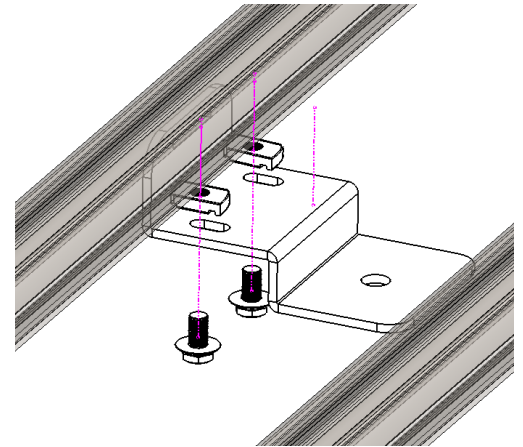

Item used in this step

Item 1	Aerial Mount Holder
Item 3	M10 Unistrut
Item 5	M10 x 20 Stainless Hex Bolt

2

- Insert the Support plate to the slot of the holder on the cross bar and using the channel nuts and M10 Dacro Bolt to assemble. Refer to the diagram.

Item used in this step

Item 2	Support Plate
Item 3	M10 Unistrut
Item 4	M10 x 25 Dacro

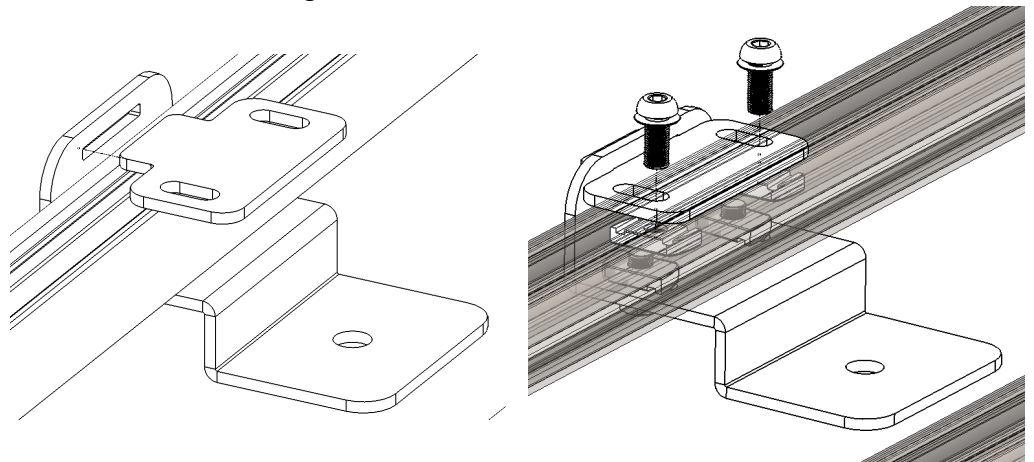

3

- Assemble the Mount Bracket with the mount holder using M16 hole.

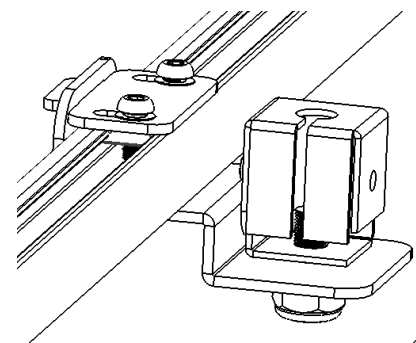

Thank you for your purchase.

Wedgetail by Tradesman Roof Racks

Innovation through Inspiration