



Mitsubishi Triton MN Wedgetail Fitting

INSTALLING RAILS AND ROOF RACK:

Congratulations on the purchase of your Australia made Wedgetail Roof Rack product, please follow these instructions to ensure correct fitment.

Mounting Lug Installation

1. Starting at the front of the vehicle remove the rubber mould that sits inside the roof channel.
2. Ideally take the rails lug mounting hole centre to 370mm from the Wind Screen. Mark the rail mounting holes with a marker.

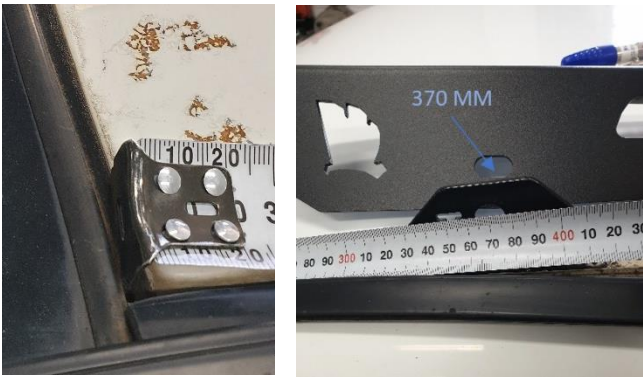

3. Position the Wedgetail rails in the location aligned with the marked hole and mark the 2nd hole accordingly.



4. Place the Lug centrally aligned with the mark and mark the rivet mounting holes. Repeat the same for all other lugs.

5. When drilling rivet mounting holes ensure you use a sleeve or spacers on your drill to ensure headlining, wiring or curtain airbags are not damaged.
6. Apply silicone or similar urethane sealant to the drilled holes.
7. Mount all the Lugs as shown, in the holes using Rivets Making sure to line up the front and rear lug with each other, then tighten.

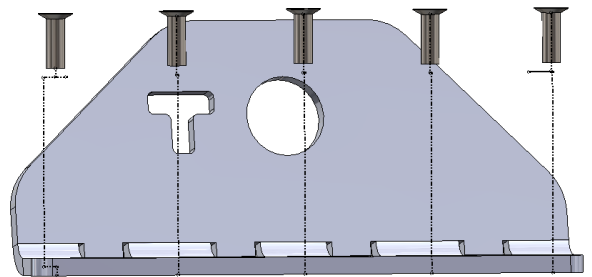

This fitment uses Structural Non-Sealed rivets for strengthening reasons



Silicon must be applied to the top of the rivet to prevent water ingress.

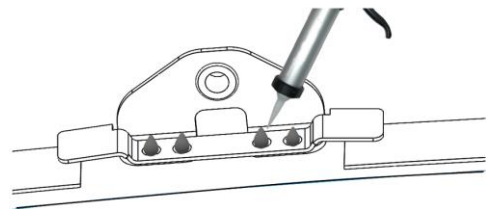

*Image can be different from the actual lugs and cover plates provided.

8. Attach Rails to lugs using 10mm hardware with the wedgetail logo facing to the front of the vehicle. Refer to the diagram (do not tighten fully).

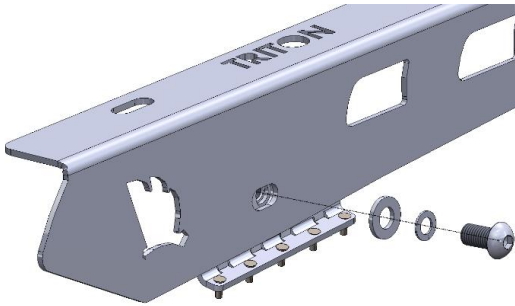

9. Fit 10mm Bolt / Split washer / Flat washer / Channel Nuts to the top of rail.

**Channel nuts to the top as shown in the next diagram*

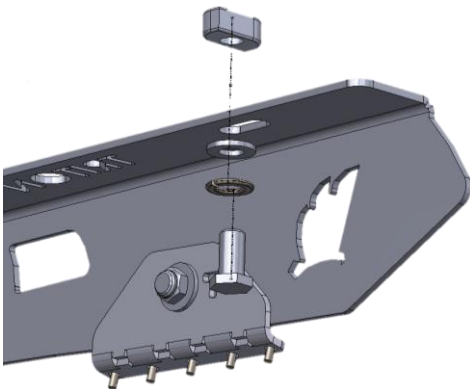

10. Centralize the rack side to side (using a tape measure) on the wedgetail rails.
11. Fully tighten remaining bolts in the following order:

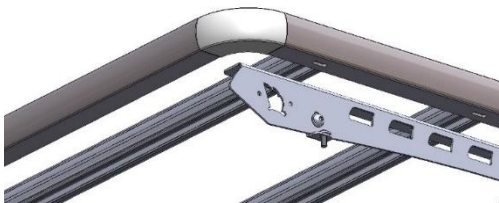

- i) Rail to the Lug
 - ii) Rails to Platform
- * ensure the channel nuts are 90 degree to the channels*
- iii) Attach Wind Deflector

**Check fastenings are firmly tensioned at regular intervals
Do not overtighten, this will preserve the spring washers.**

Thank you for your purchase

Please complete your warranty application following correct installation

Wedgetail by Tradesman Roof Racks

Innovation through Inspiration