

Wedgetail Rails and Platform Fitting Instruction

To suit Volkswagen Amarok 2023 - Onward Dual Cab



WT-VA2-1412

Congratulations on the purchase of your Australian made Wedgetail Roof Rack product.

Please read and follow the instructions carefully to ensure correct fitment.

Contact us if any parts appear missing, incorrect, or damaged.

Tools Required:

- Allen key (6 mm)
- Spanner (17mm)
- Drill bit (5mm)
- Panel Lever
- Marker
-

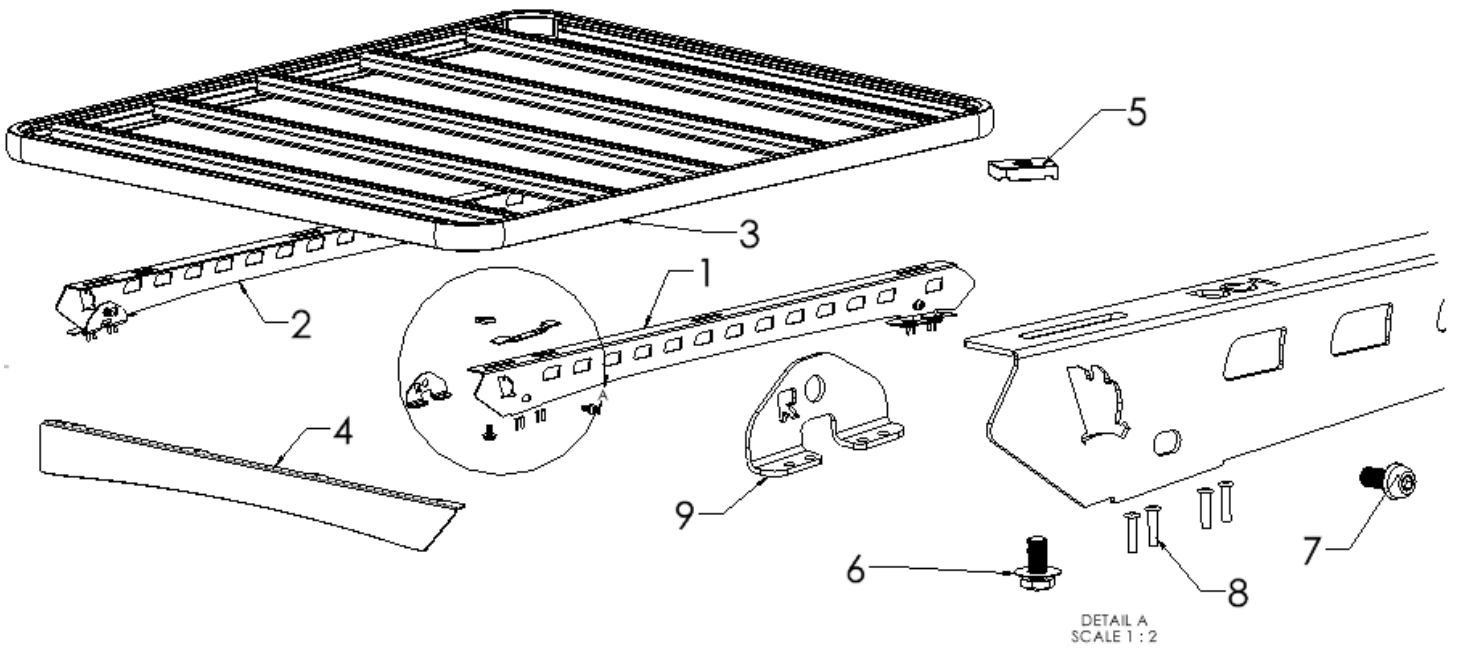

KIT CONTENTS					
ITEM	COMPONENT	QTY	ITEM	COMPONENT	QTY
1	Amarok Gen2 Wedgetail Left Rails	1	7	M10 Dacro Sems Dome Head	4
2	Amarok Gen2 Wedgetail Right Rails	1	8	16 mm Rivets	16
3	Wedgetail Pre-assemble Platform	1	9	PX Ranger Lug	4
4	Wedgetail Wind Deflector & kits	1			
5	M10 Unistrut	6			
6	M10 X 20 Stainless Hex Bolt	6			

Locating the mounting position

1

- The photos below indicate where the mountings are to be positioned and the roof channel rubber should be cut to allow the Wedgetail Rail mounting lugs to be riveted within the roof channel.
- Mark the mounting location with a suitable marker on the roof rubber

Centre of Front Mounting Lug approx. 290 mm from windscreen edge

Centre distance between Front Mounting Lug & Rear Mounting Lug 995mm

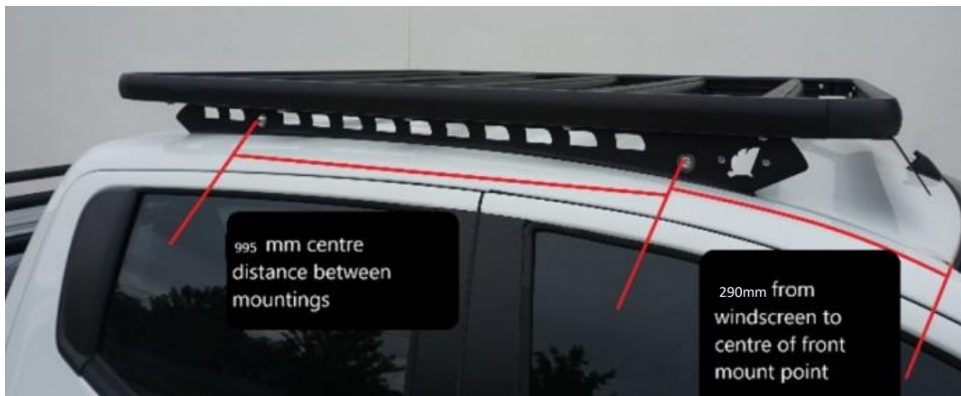

2

- Make the first cut to the rubber along the seam-line, found near the ends of the rubber (Towards the back of the cabin)
- Place a mounting lug where the first cut was made, and use that to measure the next cut on the inner seam of the rubber. Cut out the inner seam of the rubber to fit over the top of the mounting lug
- Drill all 4 mounting holes in each lug using a 5mm drill with drill stop, drilling one at a time then placing a rivet through hole to keep lined up (DO NOT RIVIT IN PLACE YET) before drilling the next.



When drilling rivet mounting holes ensure you use a Drill stop on your drill to ensure headlining, wiring or curtain airbags are not damaged.

3

- Paint all holes using either an enamel or acrylic paint (to apply you can use a cotton bud if paint brush is not available).
- Apply silicone or urethane sealer (natural cure sealants only) to the 5mm drilled rivet holes.
- Attach lugs to the roof of vehicle using 5mm rivets and as shown.

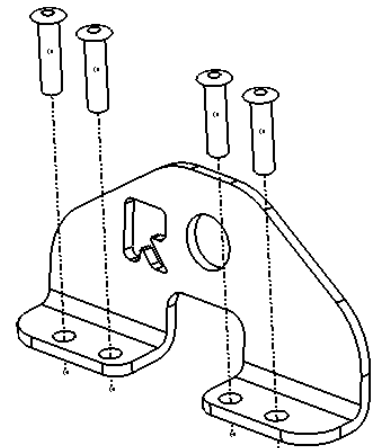

Wedgetail Rails and Platform Fitting Instruction

To suit Volkswagen Amarok 2023 - Onward Dual Cab



WT-VA2-1412

4

- Move the rubber out the way and attach the rail to mounting lug as a guide for the placement of the front mounting lug
- Mark the hole you need to drill using the bracket and repeat Step 2-3
- Remove the inner seam cut roughly 5mm of rubber where the bracket will sit, to ensure the rubber fits over the brackets

5

- Repeat Step 2-4 again on another side
- Clean the roof and rubber of any dirt / loose rubber pieces from cutting

6

- Attach Rails to lugs using 10mm hardware with the wedgetail logo facing to the front of the vehicle. Refer to the picture.

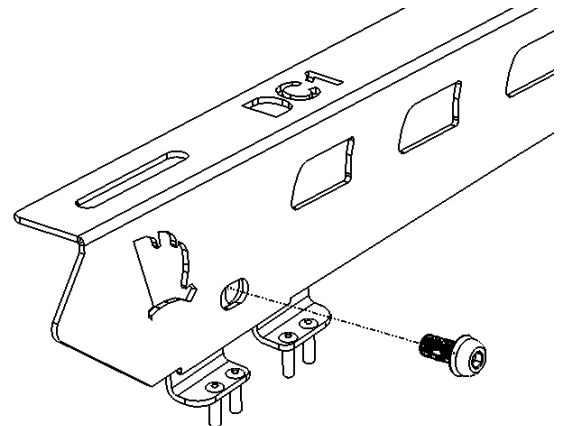

7

- Attach the channel nuts to the top of rail.
- Fit 10mm Bolt / Split washer / Flat washer / Channel Nuts to the top of rail.

* Channel nuts to the top as shown in the following diagram

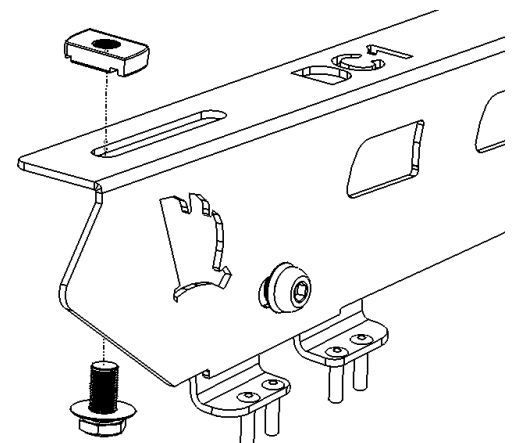



Assemble the Wedgetail Platform to the rails

8

- Place the Wedgetail Platform on the rails (Wind deflector mounting towards the front of vehicle), then spin the channel nuts 90 degree in the channel on the underside of the rack till they lock into the channels. Do not tighten fully.

9

- Centralize the rack side to side (using a tape measure) on the wedgetail rails.

10

- Fully tighten remaining bolts in the following order:
 1. Rails to the lugs
 2. Rails to platform
 3. Attach wind Deflector.

NOTE-Ensure the channel nuts are 90 degrees to the channels.



Check fastenings are firmly tensioned at regular intervals.

Do not overtighten, this will preserve the spring washers.

Thank you for your purchase.

Please complete your warranty application following correct installation.

Wedgetail by Tradesman Roof Racks

Innovation through Inspiration